

10" Cabinet Saw Sliding Table

Model: 10-110B/E

RIKON POWER TOOLS



Owner's Manual

Record the serial number and date of purchase
in your manual for future reference.

Serial number: _____

Date of purchase: _____

For more information:

www.rikontools.com or info@rikontools.com

For Parts or Questions:

techsupport@rikontools.com or 877-884-5167

Operator Safety: Required Reading

IMPORTANT! Safety is the single most important consideration in the operation of this equipment. **The following instructions must be followed at all times.**

There are certain applications for which this tool was designed. We strongly recommend that this tool not be modified and/or used for any other application other than that for which it was designed. If you have any questions about its application, do not use the tool until you have contacted us and we have advised you.

General Safety Warnings

KNOW YOUR POWER TOOL. Read the owner's manual carefully. Learn the tool's applications, work capabilities, and its specific potential hazards.

⚠ DANGER



ALWAYS GROUND ALL TOOLS.

If your tool is equipped with a three-pronged plug, you must plug it into a three-hole electric receptacle. If you use an adapter to accommodate a two-pronged receptacle, you must attach the adapter plug to a known ground. Never remove the third prong of the plug.

ALWAYS AVOID DANGEROUS ENVIRONMENTS.

Never use power tools in damp or wet locations. Keep your work area well lighted and clear of clutter.

⚠ DANGER



ALWAYS REMOVE THE ADJUSTING KEYS AND WRENCHES FROM TOOLS AFTER USE.

Form the habit of checking to see that keys and adjusting wrenches are removed from the tool before turning it on.

ALWAYS KEEP YOUR WORK AREA CLEAN. Cluttered areas and benches invite accidents.

⚠ DANGER



ALWAYS KEEP VISITORS AWAY FROM RUNNING MACHINES.

All visitors should be kept a safe distance from the work area.

ALWAYS MAKE THE WORKSHOP CHILDPROOF.

Childproof with padlocks, master switches, or by removing starter keys.

⚠ DANGER



NEVER OPERATE A TOOL WHILE UNDER THE INFLUENCE OF DRUGS, MEDICATION, OR ALCOHOL.

⚠ DANGER



ALWAYS WEAR PROPER APPAREL.

Never wear loose clothing or jewelry that might get caught in moving parts. Rubber-soled footwear is recommended for the best footing.

⚠ DANGER



ALWAYS USE SAFETY GLASSES AND WEAR HEARING PROTECTION.

Also use a face or dust mask if the cutting operation is dusty.

⚠ DANGER



NEVER OVERREACH.

Keep your proper footing and balance at all times.

⚠ DANGER



NEVER STAND ON TOOLS.

Serious injury could occur if the tool is tipped or if the cutting tool is accidentally contacted.

⚠ DANGER**ALWAYS DISCONNECT TOOLS.**

Disconnect tools before servicing and when changing accessories such as blades, bits, and cutters.

**ALWAYS AVOID ACCIDENTAL STARTING.**

Make sure switch is in "OFF" position before plugging in cord.

NEVER LEAVE TOOLS RUNNING UNATTENDED.**⚠ DANGER****ALWAYS CHECK FOR DAMAGED PARTS.**

Before initial or continual use of the tool, a guard or other part that is damaged should be checked to assure that it will operate properly and perform its intended function. Check for alignment of moving parts, binding of moving parts, breakage of parts, mounting, and any other conditions that may affect its operation. A guard or other damaged parts should immediately be properly repaired or replaced.



Table Saw Safety Rules

1. Always wear eye protection.
2. Keep hands away from the saw blade while machine is running.
3. Always use blade guard during normal cutting operations.
4. Always use splitter during normal cutting operations.
5. Use push sticks when ripping narrow stock.
6. Always use fence while ripping and miter gauge while cross-cutting.
7. Never reach over or behind saw blade while machine is running.
8. Do not remove cut-off or jammed pieces until blade has come to a full stop.
9. Disconnect machine from power source before making repairs or adjustments.
10. Do not expose saw or power cord to water or use in damp locations.

SAVE THESE INSTRUCTIONS.
Refer to them often.

Table of Contents

Safety Warnings.....	2-3
Table Saw Safety Rules	3
Specifications	4
Contents of Package	5
Unpacking and Checking Contents	5-6
Getting To Know Your Sliding Table	7
Assembly	8-12
Adjustment.....	12-13
Operation.....	13-14
Rip Fence Installation.....	15
Maintenance	15
Troubleshooting.....	16
Parts Diagram.....	17
Parts List.....	18
Warranty	19

Specifications

Minimum Table Travel	12"
Maximum Table Travel	49"
Sliding Table Dimension	51-12" x 9-7/8"
Miter Fence Length	49-1/4"
Miter Fence Angles	0-45° Forward/Back
Sliding Carriage Size	18-1/4" x 23-3/4"

Content of Package

Model 10-110B/E 10" Table Saw Sliding Table is shipped complete in 2 boxes.

Unpacking and Checking Contents

Separate all "loose parts" from packaging materials and check each item with "Table of Loose Parts" to make sure all items are accounted for, before discarding any packaging material.

TABLE OF LOOSE PARTS

Item	Part Name	Qty
A	Sliding Table	1
B	Miter Fence	1
C	Loose Parts Bag	1

Box #1

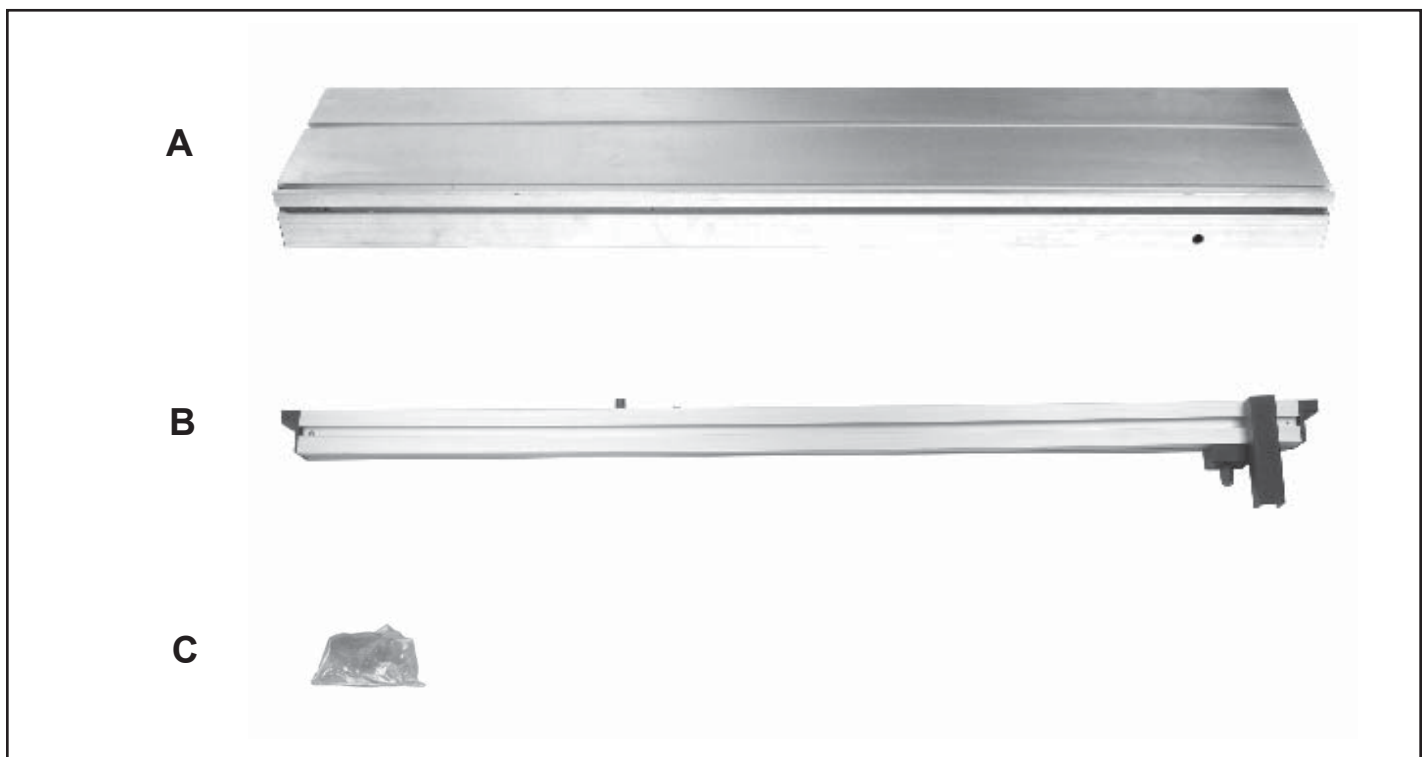
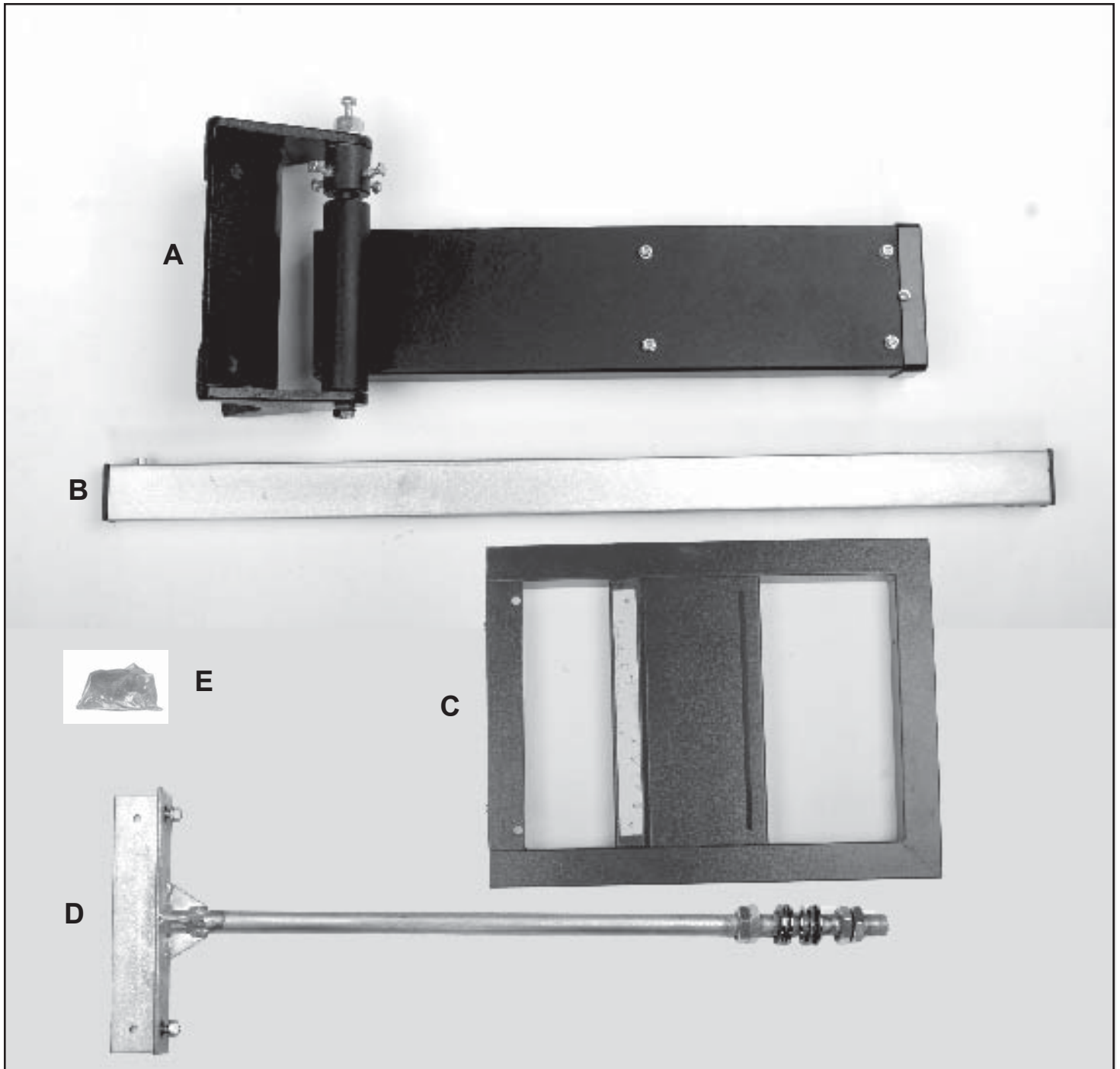

TABLE OF LOOSE PARTS

Item	Part Name	Qty
A	Swing Arm Assembly	1
B	Swing Arm Extension Bar	1
C	Sliding Table Carriage	1
D	Sliding Table Support Arm	1
E	Loose Parts Bag	1

Box #2



Getting To Know Your Sliding Table



1. Flip Stop
2. Miter Fence
3. Sliding Table
4. Sliding Table Locking Pin
5. Push Block
6. Slide Handle
7. Swing Arm Assembly
8. Carriage Table Support Arm
9. Sliding Table Carriage

Mounting the Swing Arm Bracket

1. Open the motor cover located at the left side of the saw.
 2. With assistance hold the swing arm bracket against the saw body and attach using four 8MM hex bolts, four 8MM washers and four 8MM hex nuts.
 3. Slide the four 8MM hex bolts through the bracket and saw body and attach using the four 8 washers and four 8MM hex nuts from inside the saw body.
- Figure 1.

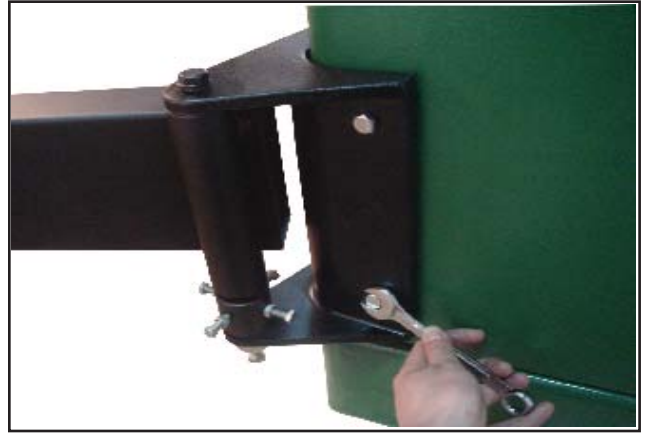

Figure 1

Installing the Swing Arm Extension Bar

1. Slide the swing arm extension bar through the swing arm bracket making sure that the large hole is installed first and that the set screw is pointing downward. Figure 2.



Figure 2

Mounting the Sliding Table

1. Locate the sliding table mounting hardware which includes two knobs, two T-nuts, two 8MM washers and two adjusting plates. Figure 3.
2. Assemble the hardware as shown (Fig. 3) and slide the T-nut into the track (Fig. 4) making sure that the clamp plate is against the bottom of the table assembly.

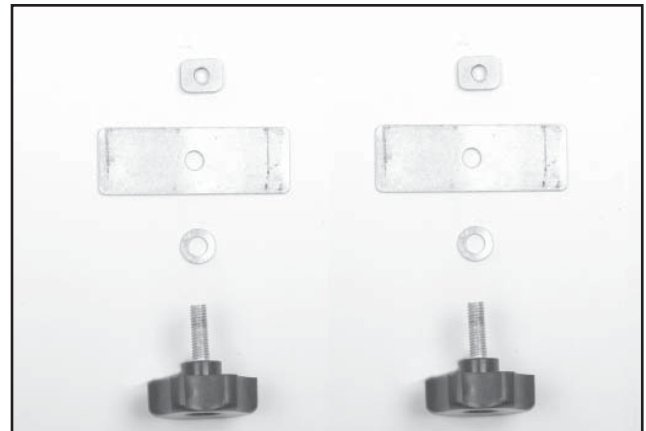

Figure 3



Figure 4

Mounting the Sliding Table Continued

3. Slide the hardware toward the cast mounting bracket located on the saw body. Place the adjusting plate on top of the set screws as shown (A, Fig.5).

4. Tighten the lock knob slightly, leaving loose for adjustment.

5. Repeat procedure for rear mounting bracket.

6. Adjusting the parallel of the saw table and sliding table with the four set screws (A, Fig.5).

Installing the Sliding Table Carriage

1. Locate the sliding table carriage mounting hardware as shown. Figure 6.

2. Slide the T-nuts bar into the side channel of the sliding table. Figure 7.

3. Attach the carriage table support arm to the bottom the the sliding table carriage using two 8MM carriage bolts, two 8MM washers and two 8MM hex bolts. The head of the carriage bolts should lock into the bottom of the sliding table carriage. Finger tighten the two 6MM hex bolts only until next step is completed. Figure 8.

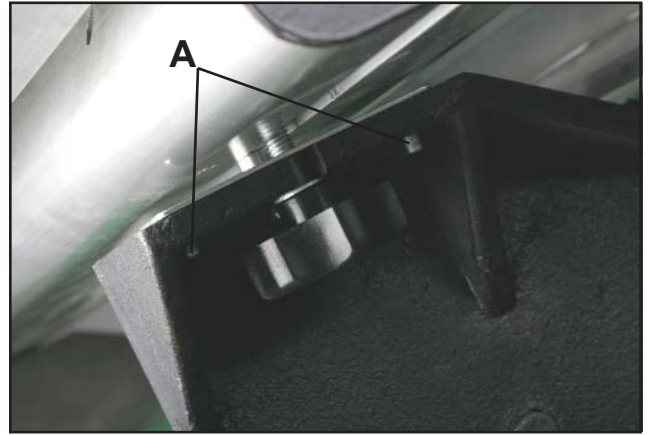

Figure 5

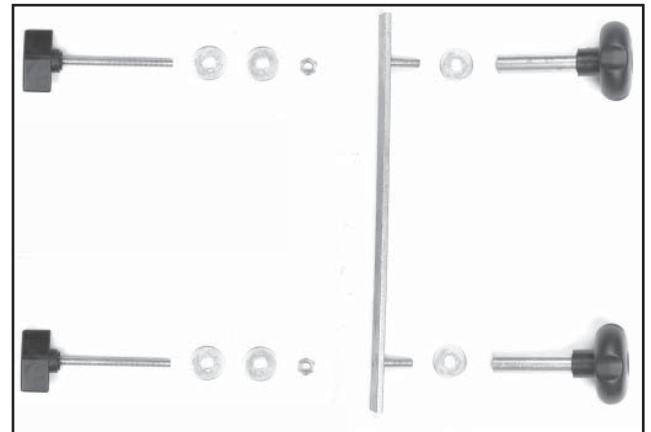

Figure 6



Figure 7

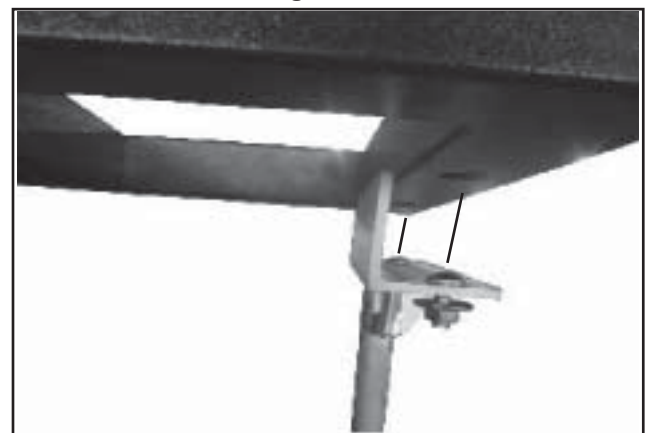

Figure 8

Assembly

Carriage Table Support Arm Installation

1. Insert the support arm into the swing arm extension bar as shown (A, Fig. 9) making sure that bearing assembly rests between the adjusting nuts and the swing arm extension bar (B, Fig. 9).

Reminder: Tighten the carriage bolts shown in Figure 8 on page nine once the support arm is installed.

2. Hold the support arm in place by installing the second bearing set and adjusting nuts as shown. The second set of bearings should be installed against the bottom side of swing arm extension bar. Figure 10.

NOTE: Do not overtighten the adjusting nuts as the bearings will bind and the table will not slide smoothly.

3. Hold the sliding table carriage against the sliding table and install the lock knobs through the carriage to the T-nuts bar in the sliding table channel. Figure 11.

4. Line up the two holes in the side of the support arm with the two holes in the side of the sliding table carriage (Fig. 12).

5. Insert the two locking knobs with the long threaded ends as well as two 6MM washers through the support arm and through the sliding table carriage (Fig. 12). Attach with with two 6MM washers and two 6MM hex nuts.

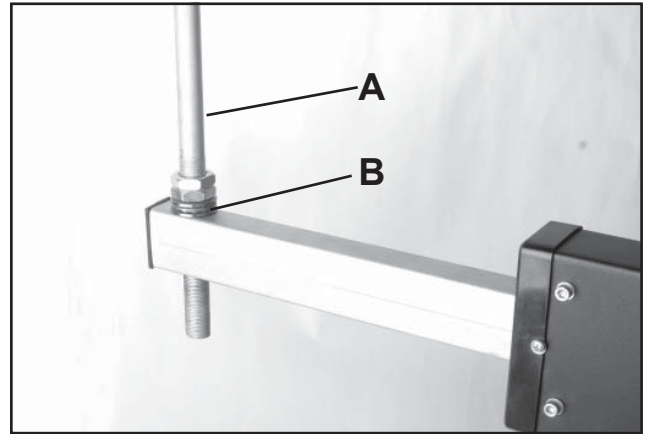

Figure 9



Figure 10



Figure 11



Figure 12

Assembly

Installing the Sliding Table Miter Fence

1. Locate the miter fence (A, Fig. 13) and miter fence locking knob (B, Fig. 13) as shown.

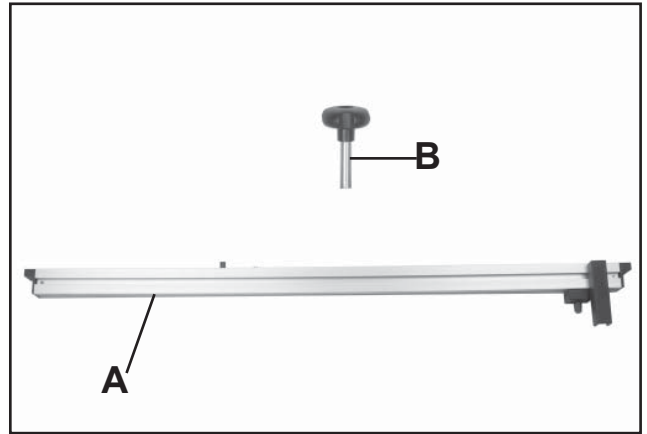

Figure 13

2. Lay the miter fence on top of the sliding table carriage and place the rotation shaft into the hole on the sliding table carriage. Figure 14.



Figure 14

3. Install the miter fence locking knob from the underneath of the sliding table carriage. Figure 15.



Figure 15

Assembly

Installing the Sliding Table Locking Pin

1. Locate the locking pin with the black handle and thread it through the sliding table body with wrench as shown. Figure 17.

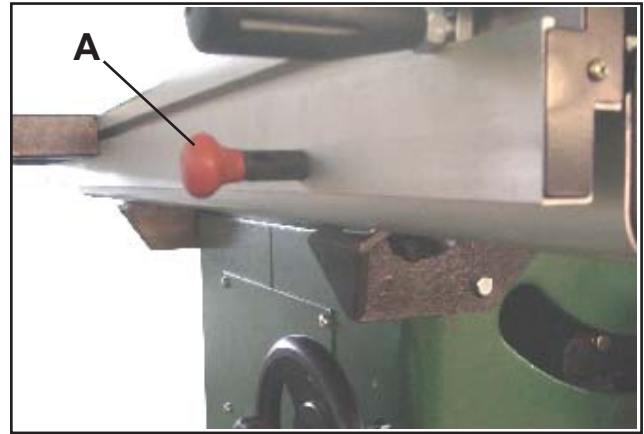

Figure 17

Adjustment

Leveling the Sliding Table to the Saw

NOTE:

The sliding table should be set approximately 3/64" of an inch higher than the saw table to prevent sheet goods from binding against the table.

1. Loosen the two sliding table lock knobs slightly. (B, Fig. 18)
2. Adjust the set screws accordingly which will place pressure against the pressure plate (A, Fig. 18)
3. Tighten the sliding table lock knobs and check adjustment. Repeat if necessary.

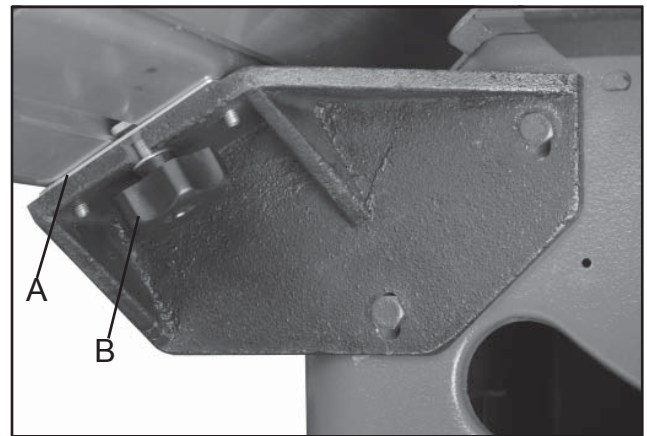

Figure 18

Leveling the Sliding Table Carriage

1. Loosen the lower adjusting nuts on the carriage table support arm (A, Fig. 19).
2. Raise or lower the upper adjusting nuts until the sliding table carriage is level (B, Fig. 19).
3. Tighten the lower adjusting nuts and check table for level. Repeat if necessary.

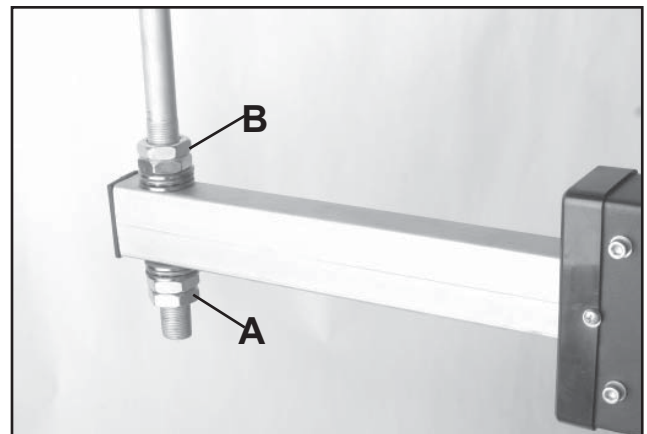

Figure 19

Checking Sliding Table Parallel to Saw Table

After the adjustments above are completed it may be necessary to check for parallel, especially if the sliding table scrubs the saw table.

To align for parallel please repeat the steps described above. If further adjustment is needed, loosen the 8MM hex head bolts that hold the cast mounting bracket to the body of the saw. (A, Fig 20)

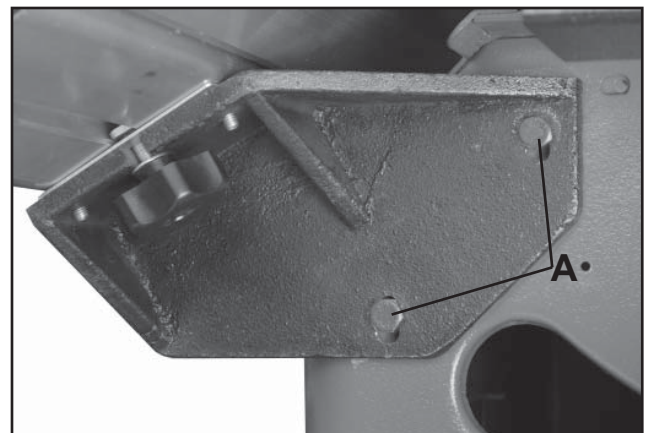

Figure 20

Adjustment

Slide Table Clearance to Saw Blade

1. Place a square on the front edge of the sliding table. (A-Fig. 20)

2. Push the sliding table until the top of the square clears the back edge of the leading tooth on the saw blade. (B-Fig. 20)

3. If the square does not clear the back edge of the leading tooth on the saw blade, loosen the two locking knobs under the slide table. Move the table support forward or backwards until the alignment is correct. (A-Fig. 21)

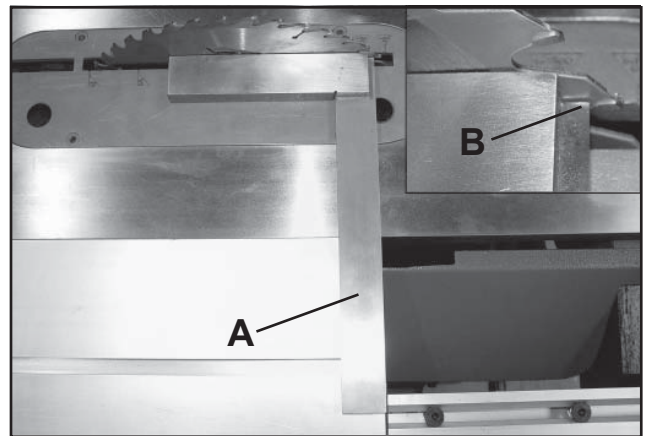

Figure 20

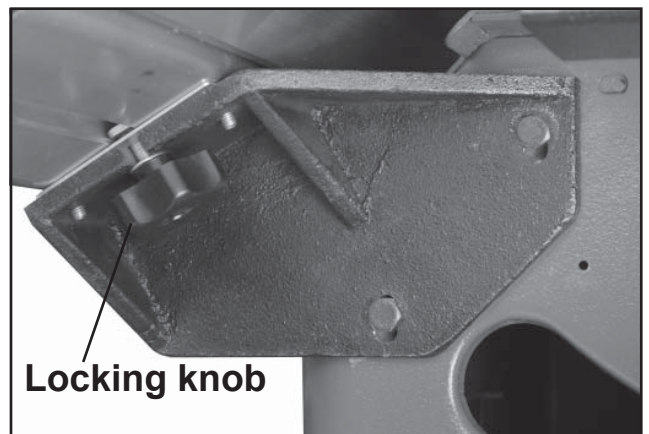

Figure 21

Operation

Locking and Unlocking the Slide Table

WARNING! Keep the sliding table locked when not in use. Failure to do so could cause serious injury.

To lock the sliding table, pull the locking pin outward, twist and insert pin into the locking hole in the table carriage. (Fig. 22)

To unlock the sliding table, pull the locking pin outward, twist and rest the cross pin into the seat of the lock knob body. (Fig. 22)

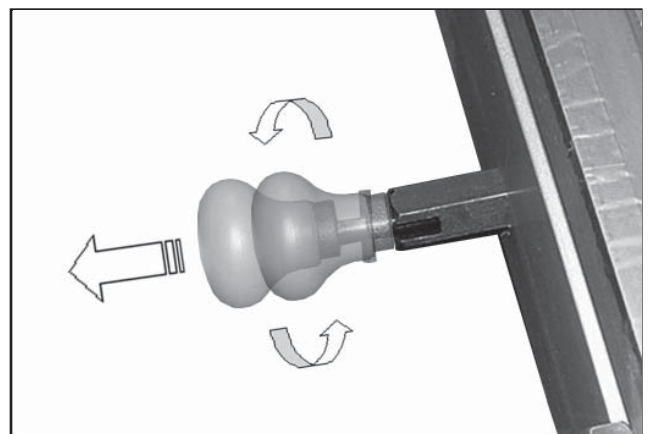

Figure 22

Cutting Sheet Goods

1. Adjust the hold down plate according to the width of material to be cut.
2. Lay the workpiece onto the table and up against the saw fence.
3. Slide the workpiece through the saw blade until the material engages the hold down plate. Walk the workpiece through the cut with the sliding table until the workpiece clears the saw blade and the cut is completed.

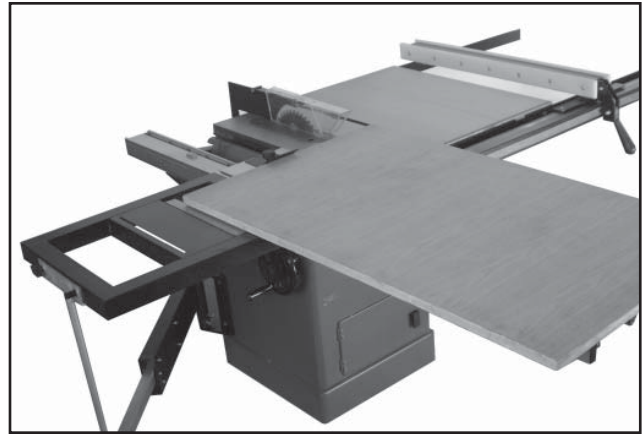

Figure 23

Cross Cutting

For cross cutting panels and narrow stock, position the miter fence onto the sliding table carriage as shown. Tighten lock knobs. (Fig. 24)

Making sure that table lock is disengaged, position the workpiece against the miter fence and push sliding table through the cut.

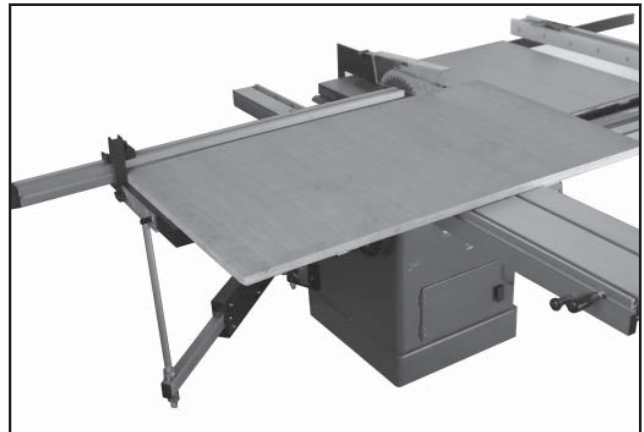

Figure 24

Miter Cuts

Loosen the lock knob on the right side of the miter fence (closest to blade) slightly and use as a pivot point. Loosen the lock knob on the left side of the miter fence and position the miter fence to the desired angle using the scale on the sliding table carriage. (Fig. 25)

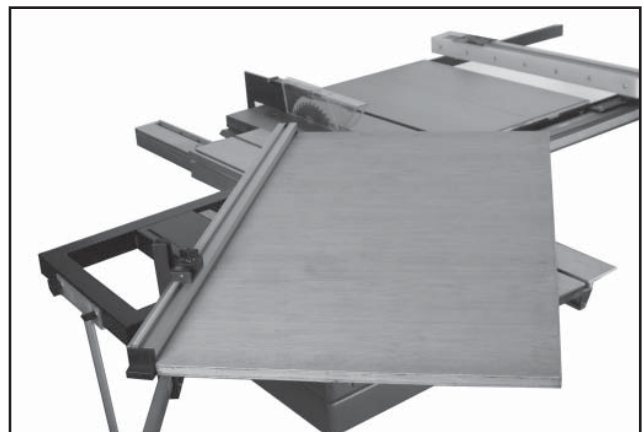

Figure 25

Rip Fence Installation

Fence Bar Placement with Sliding Table

With the sliding table installed the front and rear fence bars must be relocated. Align the notches in the fence bars with the right miter slot in the main table. (A-Fig. 26)

Follow the fence installation instructions found on page nine of the 10-110/10-050 Cabinet Saw manual.

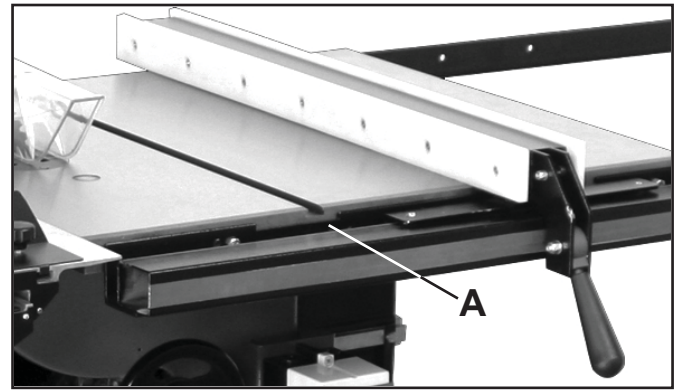

Figure 26

Maintenance

Caution! BEFORE CLEANING OR CARRYING OUT MAINTENANCE WORK, DISCONNECT THE MACHINE FROM THE POWER SOURCE (WALL SOCKET). NEVER USE WATER OR OTHER LIQUIDS TO CLEAN THE MACHINE. USE A BRUSH. REGULAR MAINTENANCE OF THE MACHINE WILL PREVENT UNNECESSARY PROBLEMS.

Keep the table clean to ensure accurate cutting.

Keep the table mounting area clean to ensure accurate operation of all moving parts and prevent excessive wear.

Check sliding table alignment to the table saw work surface to correct or prevent rubbing.

Keep the inside (near the saw blade, etc.) clean to prevent accumulation of dust.

Troubleshooting

WARNING!

FOR YOUR OWN SAFETY, ALWAYS TURN OFF AND UNPLUG THE MACHINE BEFORE CARRYING OUT ANY TROUBLESHOOTING.

SYMPTOM	POSSIBLE CAUSE	CORRECTIVE ACTION
Motor will not start.	<ol style="list-style-type: none"> 1. Low voltage. 2. Open circuit in motor or loose connections. 	<ol style="list-style-type: none"> 1. Check power line for proper voltage. 2. Inspect all lead connections on motor for loose or open connections.
Motor will not start; fuses or circuit breakers blow.	<ol style="list-style-type: none"> 1. Short circuit in line cord or plug. 2. Short circuit in motor or loose connections. 3. Incorrect fuses or circuit breakers in power line. 	<ol style="list-style-type: none"> 1. Inspect cord or plug for damaged insulation and shorted wires. 2. Inspect all connections on motor for loose or shorted terminals or worn insulation. 3. Install correct fuses or circuit breakers.
Motor overheats.	<ol style="list-style-type: none"> 1. Motor overloaded. 2. Air circulation through the fan is restricted. 	<ol style="list-style-type: none"> 1. Reduce load on motor. 2. Clean out motor to provide normal air circulation.
Motor stalls (resting in blown fuses or tripped circuit).	<ol style="list-style-type: none"> 1. Short circuit in motor or loose connections. 2. Low voltage. 3. Incorrect fuses or circuit breakers in power line. 4. Motor overloaded. 	<ol style="list-style-type: none"> 1. Inspect connections on motor for loose or shorted terminals or worn insulation. 2. Correct the low voltage conditions. 3. Install correct fuses or circuit breakers. 4. Reduce load on motor.
Machine slows when operating. Blade is not square with the slot or fence is not square to blade.	<ol style="list-style-type: none"> 1. Applying too much pressure to workpiece. 2. Belts loose. <ol style="list-style-type: none"> 1. Blade is warped. 2. Table top is not parallel to blade. 3. Fence is not parallel to blade. 	<ol style="list-style-type: none"> 1. Feed workpiece slower. 2. Tighten belts. <ol style="list-style-type: none"> 1. Replace blade. 2. Make table parallel to blade. 3. Make fence parallel to blade.
Fence hits table top when sliding on to the table.	<ol style="list-style-type: none"> 1. Front rail is bolted too low on table. 2. Rear rail is bolted too low on the table. 	<ol style="list-style-type: none"> 1. Raise front rail. 2. Raise rear rail.
Blade does not reach 90°.	<ol style="list-style-type: none"> 1. 90° stop bolt is out of adjustment. 2. Pointer bracket is hitting before the blade reaches 90°. 	<ol style="list-style-type: none"> 1. Adjust 90° stop bolt. 2. Tilt down the right side of the pointer bracket until the blade can reach 90°.
Blade hits insert at 45°	<ol style="list-style-type: none"> 1. Hole in insert is inadequate. 2. Table out of alignment. 3. Blade position is incorrect. 	<ol style="list-style-type: none"> 1. File or mill the hole in the insert. 2. Align table. 3. Adjust blade position.

For parts or technical questions contact: techsupport@rikontools.com or 877-884-5167.

Parts Diagram

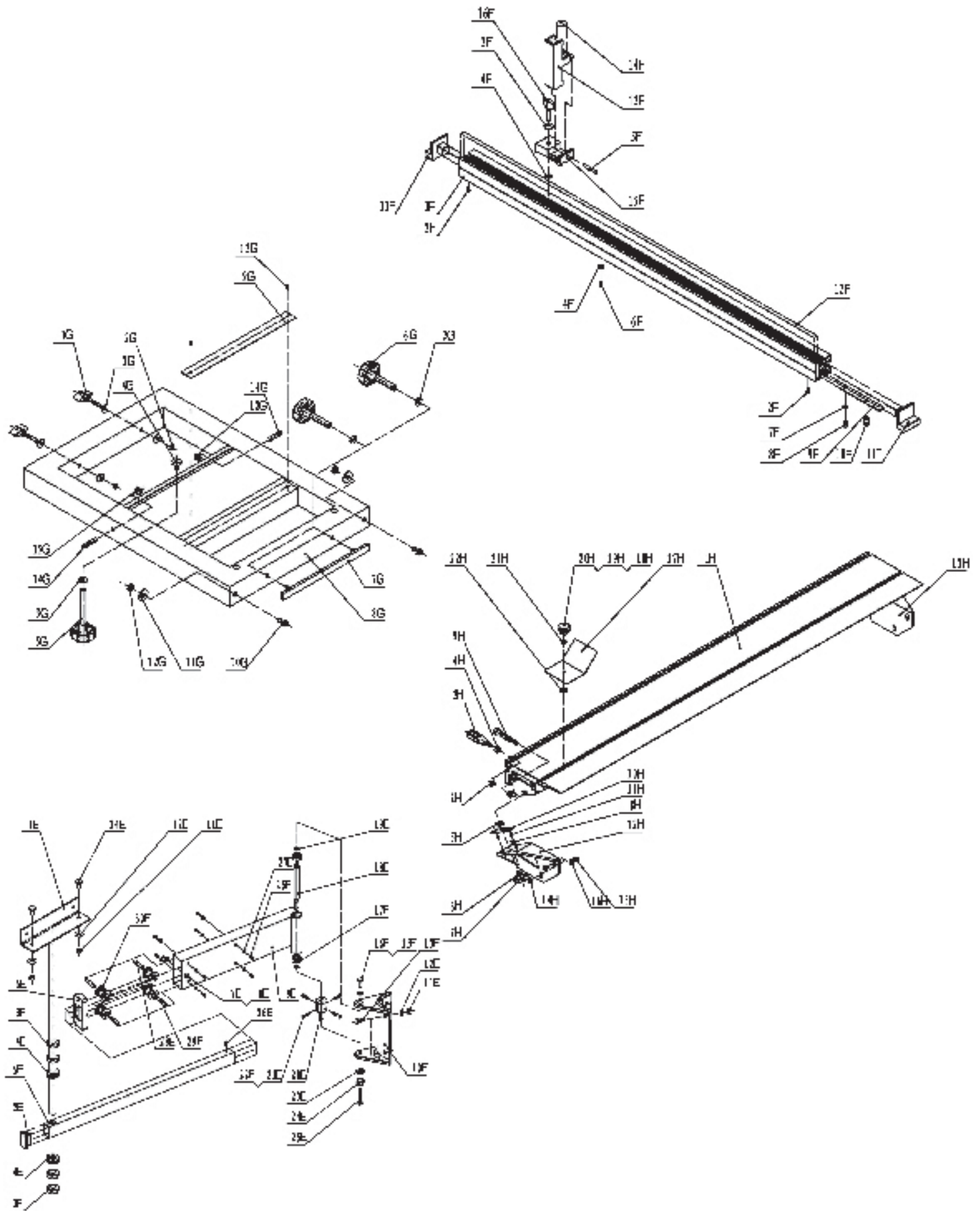

Parts List

Key No.	Part No.	Description	Key No.	Part No.	Description
1E	1-JL82236009	Support arm	13F	1-JL82213009-001Y	Flip stop
2E	1-JL82212006	End cap	14F	1-JL82213010	Magnifier
3E	1-M20GB6173	Hex nut M20	15F	1-JL82213011-001Y	Sliding block
4E	1-BRG51104GB301	Thrust bearing	16F	1-JL82213018	Thumb screw II
5E	1-JL84070002	Extension arm	1G	1-JL82213016	Thumb screw I
6E	1-JL82236002	End cap	2G	1-M6GB6170Z	Hex nut M6
7E	1-M4X8GB818Z	Hex bolt M4x8	3G	1-WSH6GB96Z	Washer 6
8E	1-WSH5GB96Z	Washer 5	4G	1-JL84100003	Clamp block
9E	1-JL82236003	Swing arm assembly	5G	1-JL84102000	Clamp handle assembly I
10E	1-JL84070001	Seat - Swing arm	6G	1-JL84102000A	Clamp handle assembly II
11E	1-M8GB6170Z	Hex nut M8	7G	1-JL84100002	Clamp plate
12E	1-WSH8GB96Z	Washer 8	8G	1-JL84101000	Sliding table frame assembly
13E	1-M8X25GB5783Z	Hex bolt M8x25	9G	1-JL84100001	Angle scale
14E	1-M8X20GB801Z	Hex bolt M8x20	10G	1-JL82233007	Position pin
15E	1-M10X25GB5781B	Hex bolt M10x25	11G	1-WSH8GB95Z	Washer 8
16E	1-WSH10GB95B	Washer 10	12G	1-M8GB6170Z	Hex nut M8
17E	1-BRG6202GB276	Bearing 6202-Z	13G	1-RVT3X7GB12618A	Rivet
18E	1-JL82236005	Shaft	14G	1-M8X40GB77B	Set screw M8X40
19E	1-CLP15GB894D1B	Retaining ring	1H	1-JL84061000	Sliding carriage
20E	1-JL82236011	Adjustable seat	2H	1-M10GB39Z	Square nut
21E	1-M6X30GB5781Z	Hex bolt M6x30	3H	1-JL26060012	Handle
22E	1-M6GB6170Z	Hex nut M6	4H	1-M10GB6170Z	Hex nut M10
23E	1-WSH16GB95Z	Washer 16	5H	1-JL82240007	Square nut
24E	1-M16GB6170Z	Hex nut M16	6H	1-WSH8GB95Z	Washer 8
25E	1-M8X60GB5781Z	Hex bolt M8X60	7H	1-JL82240011	Thumb Screw
26E	1-M6X10GB70Z	Bolt M6x10	8H	1-JL82233007	Set screw
27E	1-WSH6GB95Z	Washer 6	9H	1-JL82243000	Position handle
28E	1-JL82236006	Shaft	10H	1-JL82240010	Plate
29E	1-JL82236007	Eccentric shaft	11H	1-M6X12GB77B	Set screw M6x12
30E	1-JL82236008	Roller	12H	1-JL84060001	Support plate, front
1F	1-JL82213003	Miter fence	13H	1-JL84060002	Support plate, back
2F	1-ST3D5X9D5GB845Z	Panhead screw	14H	1-M8X20GB5781Z	Hex bolt M8x20
3F	1-WSH6GB5287Z	Washer 6	15H	1-M8GB6177D1Z	Flange nut
4F	1-JL82030006	Square nut	16H	1-WSH8GB96Z	Washer 8
5F	1-PIN6X45GB119	Pin	17H	1-JL84060003	Clamp plate
6F	1-M6X10GB77B	Set screw M6X10	18H	1-JL20061101	Knob cover
7F	1-WSH6GB95Z	Washer 6	19H	1-JL20061102	Knob body
8F	1-M6X10GB70Z	Hex screw M6X10	20H	1-M6X16GB5781Z	Bolt M6x16
9F	1-JL82213015	Guide plate	21H	1-WSH6GB96Z	Washer 6
10F	1-JL82213006	Small shaft	22H	1-JL82030006	Square nut
11F	1-JL82213007	End cap			
12F	1-JL82213008	Scale I			

RIKON

POWER TOOLS

2-Year Limited Warranty

RIKON Power Tools/Richen Enterprise, Inc. (“Seller”) warrants to only the original retail consumer/purchaser of our products that each product be free from defects in materials and workmanship for a period of two (2) years from the date the product was purchased at retail. This warranty may not be transferred.

This warranty does not apply to defects due directly or indirectly to misuse, abuse, negligence, accidents, repairs, alterations, lack of maintenance or normal wear and tear. Under no circumstances will Seller be liable for incidental or consequential damages resulting from defective products. All other warranties, expressed or implied, whether of merchantability, fitness for purpose, or otherwise are expressly disclaimed by Seller. This warranty does not cover products used for commercial, industrial or educational purposes.

This limited warranty does not apply to accessory items such as blades, drill bits, sanding discs or belts and other related items.

Seller shall in no event be liable for death, injuries to persons or property, or for incidental, contingent, special, or consequential damages arising from the use of our products.

To take advantage of this warranty proof of purchase documentation, which includes date of purchase and an explanation of the complaint, must be provided.

The Seller reserves the right to effect at any time, without prior notice, those alterations to parts, fittings, and accessory equipment which they may deem necessary for any reason whatsoever.

To take advantage of this warranty, please fill out the enclosed warranty card and send it to:
RIKON Warranty
110 Cummings Park
Woburn, MA 01801

The card must be entirely completed in order for it to be valid. If you have any questions please contact us at 877-884-5167 or warranty@rikontools.com.

RIKON **POWER TOOLS**

**For more information:
110 Cummings Park
Woburn, MA 01801**

**877-884-5167/781-933-8400
techsupport@rikontools.com
www.rikontools.com**