

# RIKON POWER TOOLS

**Mini Lathe  
Model: 70-100**



Record the serial number and date of purchase  
in your manual for future reference.

Serial number: \_\_\_\_\_

Date of purchase: \_\_\_\_\_

For more information:  
[www.rikontools.com](http://www.rikontools.com) or [info@rikontools.com](mailto:info@rikontools.com)  
For Parts or Questions:  
[techsupport@rikontools.com](mailto:techsupport@rikontools.com) or 877-884-5167









# Safety Warning

**IMPORTANT!** Safety is the single most important consideration in the operation of this equipment. **The following instructions must be followed at all times.**

There are certain applications for which this tool was designed. We strongly recommend that this tool not be modified and/or used for any other application other than that for which it was designed. If you have any questions about its application, do not use the tool until you have contacted us and we have advised you.

## General Safety Warnings

**KNOW YOUR POWER TOOL.** Read the owner's manual carefully. Learn the tool's applications, work capabilities, and its specific potential hazards.

 <b>⚠ DANGER</b>	<b>ALWAYS GROUND ALL TOOLS.</b> If your tool is equipped with a three-pronged plug, you must plug it into a three-hole electric receptacle. If you use an adapter to accommodate a two-pronged receptacle, you must attach the adapter plug to a known ground. Never remove the third prong of the plug.  <b>ALWAYS AVOID DANGEROUS ENVIRONMENTS.</b> Never use power tools in damp or wet locations. Keep your work area well lighted and clear of clutter.
 <b>⚠ DANGER</b>	<b>ALWAYS REMOVE THE ADJUSTING KEYS AND WRENCHES FROM TOOLS AFTER USE.</b> Form the habit of checking to see that keys and adjusting wrenches are removed from the tool before turning it on.  <b>ALWAYS KEEP YOUR WORK AREA CLEAN.</b> Cluttered areas and benches invite accidents.
 <b>⚠ DANGER</b>	<b>ALWAYS KEEP VISITORS AWAY FROM RUNNING MACHINES.</b> All visitors should be kept a safe distance from the work area.  <b>ALWAYS MAKE THE WORKSHOP CHILDPROOF.</b> Childproof with padlocks, master switches, or by removing starter keys.
 <b>⚠ DANGER</b>	<b>NEVER OPERATE A TOOL WHILE UNDER THE INFLUENCE OF DRUGS, MEDICATION, OR ALCOHOL.</b>
 <b>⚠ DANGER</b>	<b>ALWAYS WEAR PROPER APPAREL.</b> Never wear loose clothing or jewelry that might get caught in moving parts. Rubber-soled footwear is recommended for the best footing.
 <b>⚠ DANGER</b>	<b>ALWAYS USE SAFETY GLASSES AND WEAR HEARING PROTECTION.</b> Also use a face or dust mask if the cutting operation is dusty.
 <b>⚠ DANGER</b>	<b>NEVER OVERREACH.</b> Keep your proper footing and balance at all times.
 <b>⚠ DANGER</b>	<b>NEVER STAND ON TOOLS.</b> Serious injury could occur if the tool is tipped or if the cutting tool is accidentally contacted.

**⚠ DANGER****ALWAYS DISCONNECT TOOLS.**

Disconnect tools before servicing and when changing accessories such as blades, bits, and cutters.

**ALWAYS AVOID ACCIDENTAL STARTING.**

Make sure switch is in "OFF" position before plugging in cord.

**NEVER LEAVE TOOLS RUNNING UNATTENDED.****⚠ DANGER****ALWAYS CHECK FOR DAMAGED PARTS.**

Before initial or continual use of the tool, a guard or other part that is damaged should be checked to assure that it will operate properly and perform its intended function. Check for alignment of moving parts, binding of moving parts, breakage of parts, mounting, and any other conditions that may affect its operation. A guard or other damaged parts should immediately be properly repaired or replaced.



## Special Safety Rules For Lathes

1. Do not operate this machine until you have read all of the following instructions.
2. Do not attempt to operate this machine until it is completely assembled.
3. Do not turn ON this machine if any pieces are missing.
4. If you are not familiar with the operation of the machine, obtain assistance from a qualified person.
5. It is highly recommended that this machine be firmly mounted to a flat and secure work surface.
6. Always wear protective eyewear prior to operating this machine.
7. Do not operate this machine if you are under the influence of drugs and/or alcohol.
8. Remove all jewelry prior to operating this machine.
9. Do not wear any gloves while operating this machine.
10. Always make sure the power switch is in the OFF position prior to plugging in the machine.
11. Always make sure the power switch is in the OFF position when doing any assembly or setup operation.
12. Always turn the power switch to the OFF position and let the work piece come to a complete stop prior to removal.
13. Use only sharp lathe tools.
14. The use of any accessories or attachments not recommended may cause injury to you and damage your machine.
15. This machine must be properly grounded.
16. When turning between centers, make sure headstock and tailstock are snug against work piece.
17. When face plate turning, rough-cut work piece close to the finished shape before screwing to face plate.
18. Never jam tools into work piece or take too big a cut.
19. Do not operate this machine without following all these instructions.
20. Keep these instructions for future reference.

**SAVE THESE INSTRUCTIONS.**

**Refer to them often.**

## Table of Contents

Safety Warnings.....	2
Lathe Safety Rules.....	3
Specifications.....	4
Unpacking and Contents.....	5
Getting to Know Your Lathe.....	6
Assembly.....	6
Installing the Tool Rest and Base.....	6
Installing Spindle Lock.....	7
Attaching the Spur Center.....	7
Attaching the Live Center.....	7
Installing the Faceplate.....	8
Installing the Tool Holder.....	8
Securing the Lathe to a Work Surface or Stand.....	8
Adjustments.....	8
Adjusting the Tool Rest.....	8
Adjusting the Tailstock.....	9
Changing Spindle Speeds.....	9
Typical Operations.....	9
Indexing /Spindle Lock.....	10
Maintenance.....	10
Electrical Requirements.....	11
Wiring Diagram.....	12
Troubleshooting.....	13
Explosion Diagram.....	14
Parts List.....	15
Warranty.....	16
Notes.....	17

## Specifications

Model Number	70-100
Swing Over Bed	12"
Swing Over Tool Rest Base	9-1/2"
Working Distance Between Centers	16"
Motor	1/2HP, 1Ph, 115V only
Speeds	6
Speed Ranges	430,810,1230,1810,2670,3900 RPM
Spindle Nose in x TPI	1"x 8
Headstock Taper	MT2
Tailstock Taper	MT2
Hole Through Spindle	3/8"
Ram Travel	2-1/2"
Overall Dimensions	31-3/4"(L)x18"(W)x11-1/2"(H)
Net Weight	88.5 lbs



# Contents of Package

## Unpacking and Checking Contents

Unpack your lathe from its carton and check to see that you have all of the following items. Do not turn your machine ON if any of these items are missing. You may cause injury to yourself or damage to your machine.

	Item	Description	Q'ty
	A	Lathe.....	1
	B	Knokout Bar.....	1
	C	Wrench.....	1
	D	Tool Rest.....	1
	E	Live Center.....	1
	F	Spur Center.....	1
	G	Spindle Lock Assembly.....	1
	H	Knokout Bar for Live Center pointer.....	1
	I	Tool Holder.....	1
	J	Pan head screw.....	2
	K	Manual/Warranty Card.....	1

## Tools Required for Assembly

Item	Description
	Phillips Screwdriver
	Adjustable Wrench

## Unpacking and Clean-up

1. Carefully finish removing all contents from shipping cartons. Compare contents of the shipping cartons with the list of contents above. Place parts on a protected surface.
2. Report any shipping damage to your local distributor.
3. Clean all rust protected surfaces with kerosene or diesel oil. **Do not use**; gasoline, paint thinner, mineral spirits, etc. These may damage painted surfaces.
4. Set packing material and shipping cartons to the side. **Do not discard** until machine has been set up and is running properly.

## Getting to Know Your Lathe

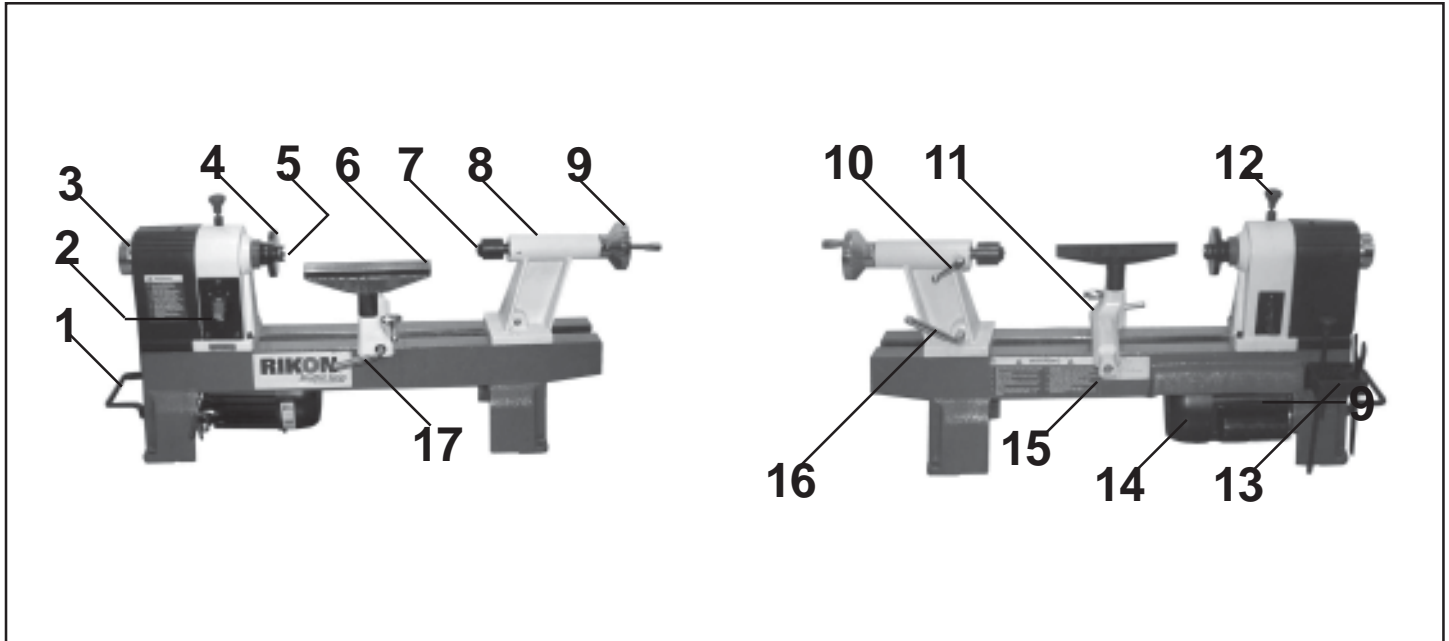

### Item Description

1	Lifting handle
2	Switch
3	Handwheel
4	Face plate
5	Spur center
6	Tool rest
7	Live center
8	Tail stock
9	Tailstock handwheel

### Item Description

10	Tailstock spindle locking arm
11	Tool rest base
12	Spindle lock
13	Tool holder
14	Motor
15	Lathe bed
16	Tailstock locking lever
17	Tool rest seat locking lever

## Assembly

The machine must not be plugged in and the power switch must be in the OFF position until assembly is complete.

### Installing Tool Rest and Base On Lathe Bed

Remove the tailstock assembly by releasing the locking handle and sliding the assembly off the end of the lathe bed.

Slide the tool rest base onto the lathe bed and reinstall the tailstock assembly.

Loosen locking arm and insert tool rest into tool rest base, adjust height up or down and tighten locking arm. (See Fig.01)

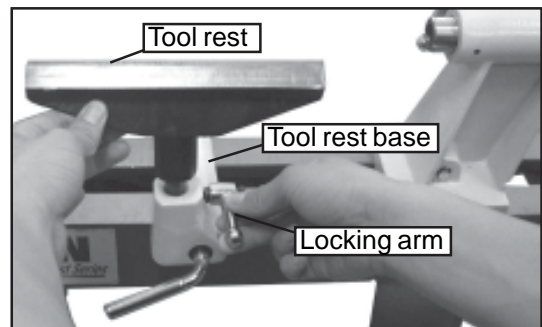

**Fig.01**

## Installing Spindle Lock

Locate the spindle lock assembly from the carton, and install it onto the head with an adjustable wrench. (See Fig.02)

**Warning:** Disengage spindle lock before turning the machine on.

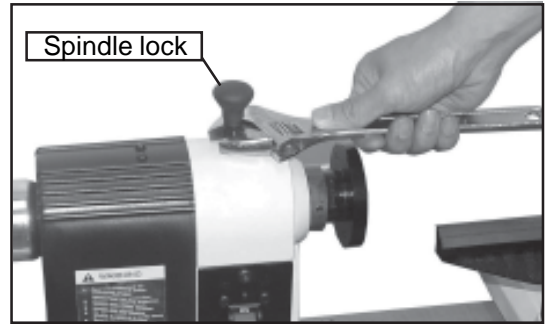

Fig.02

## Attaching Spur Center On The Headstock

Insert spur center, with a No. 2 Morse Taper shank, into the headstock spindle. (See Fig.03)

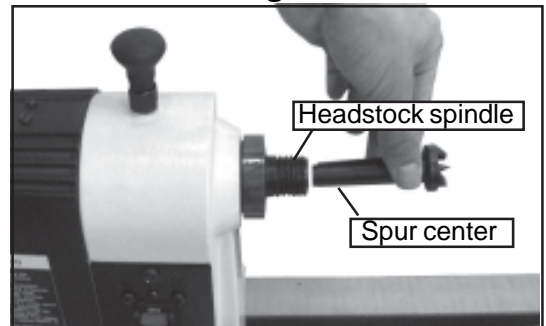

Fig.03

## Knockout Bar

The knockout bar is used to remove the spur center from the headstock spindle. Insert knockout bar into hole at opposite side from spur center. (See Fig.04)

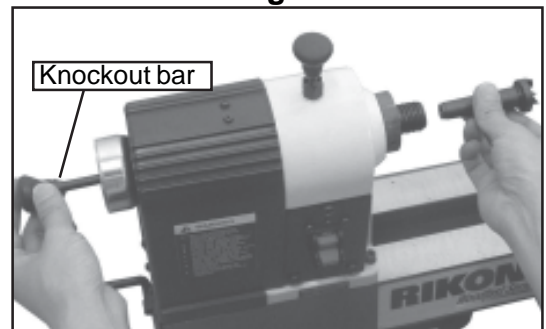

Fig.04

## Attaching Live Center On the Tailstock

Insert the live center, with a No. 2 Morse Taper shank into the tailstock spindle. (See Fig.05)

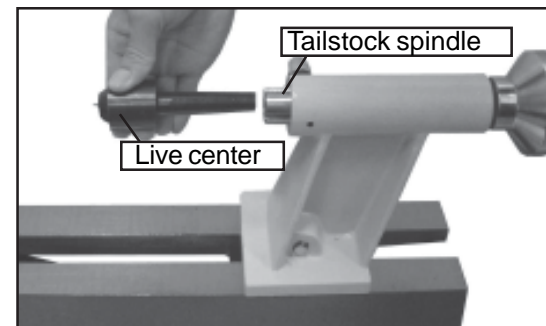

Fig.05

To remove live center from the tailstock spindle, loosen locking arm and rotate the hand wheel counter clockwise to retract spindle into the body of the tailstock. The live center will be pushed out of the spindle.

(See Fig.06)

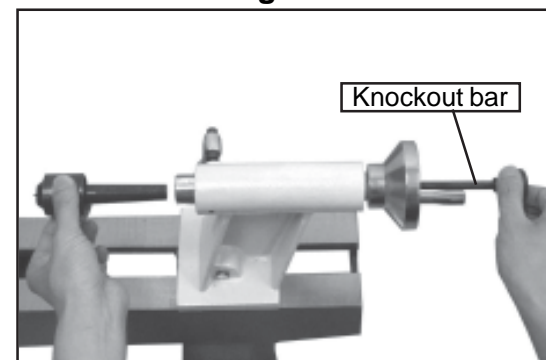

Fig.06

## Installing The Faceplate to the Headstock

Thread the faceplate clockwise on to the headstock spindle. Next, engage the spindle lock and stop the spindle from turning, and tighten faceplate with supplied wrench. (See Fig.07)

**Warning:** Disengage spindle lock before turning the machine on.

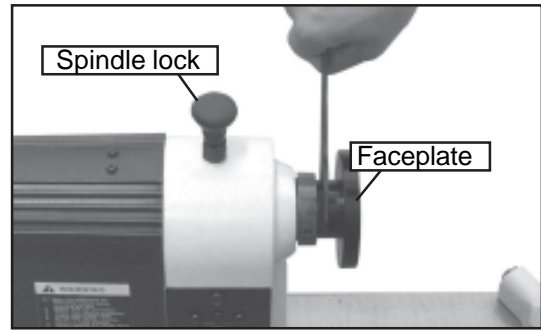

Fig.07

## Installing Tool Holder On the Lathe Bed

Locate the tool holder from the carton, and install it onto the lathe bed with two pan head screws. (See Fig.08)

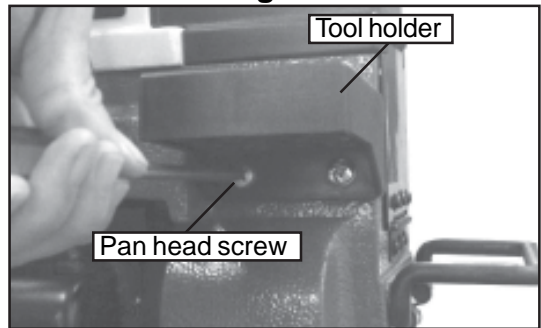

Fig.08

## Secure Lathe to a Solid Work Surface

The lathe must be attached to a solid work surface or stand. Four mounting holes are easily accessible at the base of the lathe. (See Fig.09)

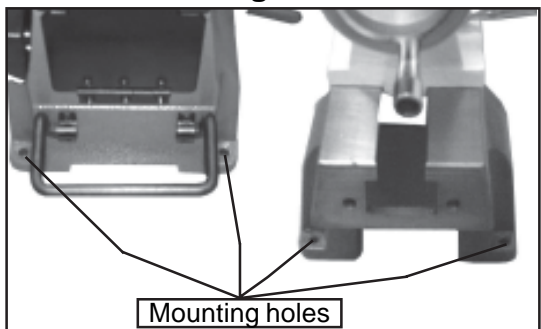

Fig.09

# Adjustments and Operations

## Adjusting the Tool Rest

The tool rest base can be easily moved along the lathe bed. Loosen locking lever counter clockwise, slide tool rest base to new position, and tighten locking lever clockwise.

To adjust the height of the tool rest, loosen locking arm, raise or lower tool rest, tighten locking arm. (See Fig.10)

**Note:** Position the tool rest as close to the work piece as possible. It should be 1/8" above the centerline of the workpiece.

To adjust clamping action of the tool rest base, remove base and adjust nut clockwise to tighten and counterclockwise to loosen. (See Fig.11)

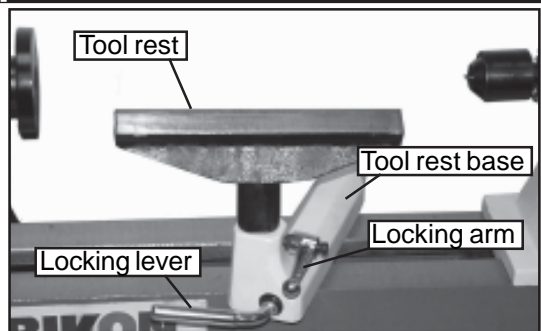

Fig.10

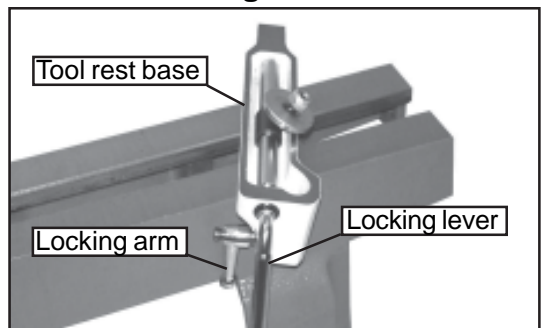

Fig.11

## Adjusting Tailstock

Loosen locking lever to move the tailstock along the lathe bed to desired position. Tighten lever.

To adjust clamping action of the tailstock, remove it from lathe bed and adjust nut clockwise to tighten and counterclockwise to loosen.(See Fig.12)

To adjust tailstock arm in or out, loosen locking arm and turn handwheel. When the tailstock arm is in a desired position, tighten locking arm. (See Fig.13)

The tailstock arm will travel from 0” to 2-1/2”

## Changing Spindle Speeds

The lathe features a six step motor and spindle pulleys to provide different spindle speeds. Open access cover to change spindle speeds. (See Fig.14)

With access cover open, loosen locking arm. Raise lever to release tension on motor pulley and tighten locking arm. Check speed and belt position chart inside access cover to determine spindle speed required.

Move drive belt to desired pulley combination. Loosen locking arm, lower lever, and the motor will provide proper tension on the drive belt. Tighten locking arm and close access cover. (See Fig.14)

## Typical Operations

The lathe is set up for a typical spindle turning operation.(See Fig.15)

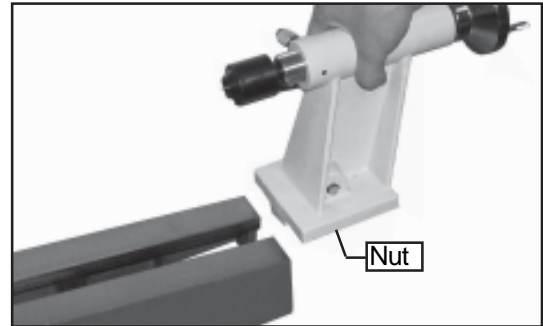

Fig.12

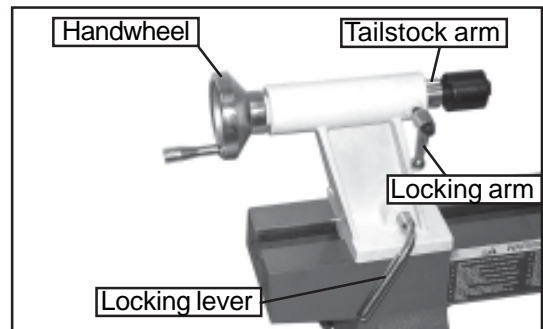

Fig.13

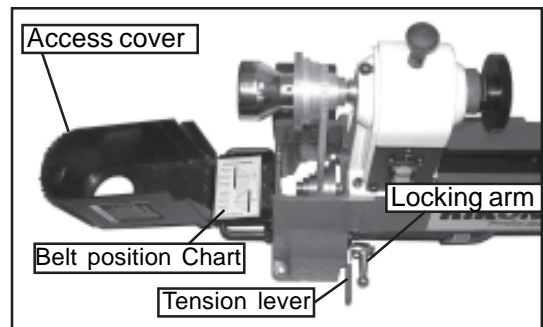

Fig.14



Fig.15

The lathe can be set up for a faceplate turning operation. The work piece should be “rough cut” as close as possible to finished shape before mounting. (See Fig.16)

## Indexing/Spindle Lock

The dual purpose indexing/spindle lock is positioned on the top of the headstock for ease of use. The headstock indexing feature has 12 equally spaced positions. The spring loaded locking pin assembly is engaged by turning the knob a half turn allowing it to drop into the desired position. To disengage, lift the lock knob up and turn a half turn either direction. (See Fig.17 & Fig.18)

The 12 position indexing feature allows accurate pattern work on projects such as straight fluting, grooving, drilling, lay out and more. This feature also allows the user to lock the spindle for removing face plates, chucks and other accessories without needing two tools.

To use the spindle lock, disengage the locking pin by lifting up and rotating a half turn. The pin will engage in the closest pin available. Once locked an accessory such as a face plate can be removed with the wrench supplied.

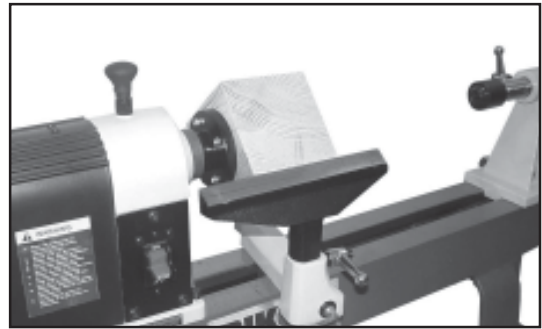

Fig.16

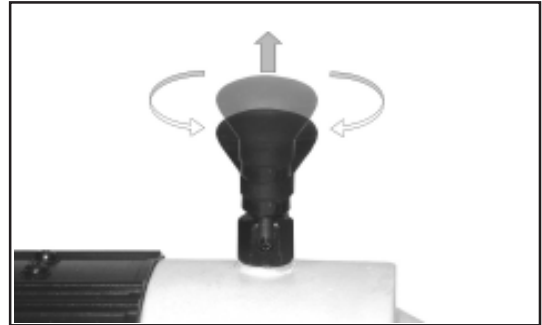

Fig.17

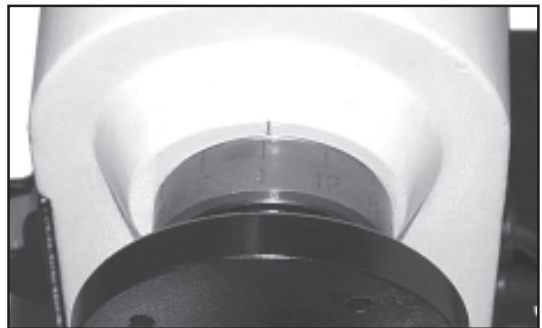

Fig.18

## Maintenance

**CAUTION! BEFORE CLEANING OR CARRYING OUT MAINTENANCE WORK, DISCONNECT THE MACHINE FROM THE POWER SOURCE (WALL SOCKET). NEVER USE WATER OR OTHER LIQUIDS TO CLEAN THE MACHINE. USE A BRUSH. REGULAR MAINTENANCE OF THE MACHINE WILL PREVENT UNNECESSARY PROBLEMS.**

Keep the lathe bed casting clean and lubricated.

Keep the outside of the machine clean to ensure accurate operation of all moving parts and prevent excessive wear.

Keep the ventilation slots of the motor clean to prevent it from overheating.

Remove all saw dust and chips from the lathe after each use.

## Electrical Requirements

In the event of a malfunction or breakdown, grounding provides a path of least resistance for electric current to reduce the risk of electric shock. This tool is equipped with an electric cord having an equipment-grounding conductor and a grounding plug. The plug must be plugged into a matching outlet that is properly installed and grounded in accordance with all local codes and ordinances.

Do not modify the plug provided. If it will not fit the outlet, have the proper outlet installed by a qualified electrician.

Improper connection of the equipment-grounding conductor can result in a risk of electric shock. The conductor, with insulation having an outer surface that is green with or without yellow stripes, is the equipment-grounding conductor. If repair or replacement of the electric cord or plug is necessary, do not connect the equipment-grounding conductor to a live terminal.

Check with a qualified electrician or service personnel if the grounding instructions are not completely understood, or if in doubt as to whether the tool is properly grounded.

Use only three wire extension cords that have three-prong grounding plugs and three-pole receptacles that accept the tool's plug.\*

Repair or replace a damaged or worn cord immediately.

This tool is intended for use on a circuit that has an outlet that looks the one illustrated in Figure A below. The tool has a grounding plug that looks like the grounding plug as illustrated in Figure A below. A temporary adapter, which looks like the adapter as illustrated in Figure B below, may be used to connect this plug to a two-pole receptacle, as shown in Figure B if a properly grounded outlet is not available.\*\* The temporary adapter should only be used until a properly grounded outlet can be installed by a qualified electrician. The green colored rigid ear or tab, extending from the adapter, must be connected to a permanent ground such as a properly grounded outlet box.

\* Canadian electrical codes require extension cords to be certified SJT type or better.

\*\* Use of an adapter in Canada is not acceptable.

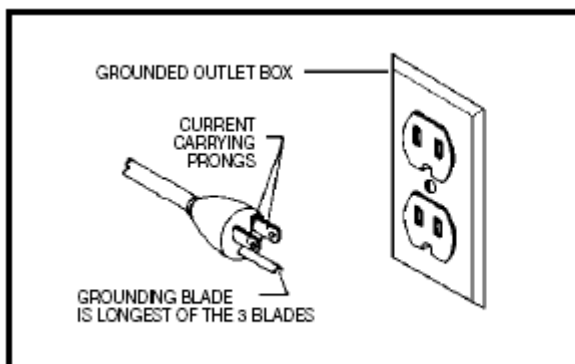

Fig. A

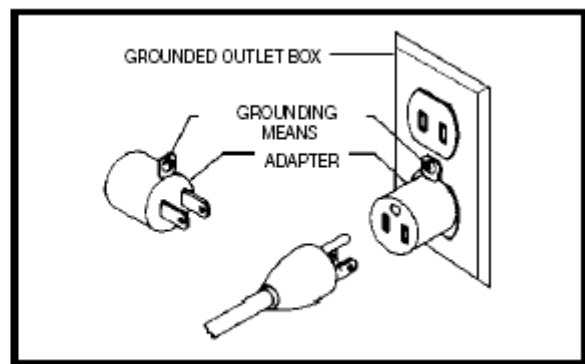
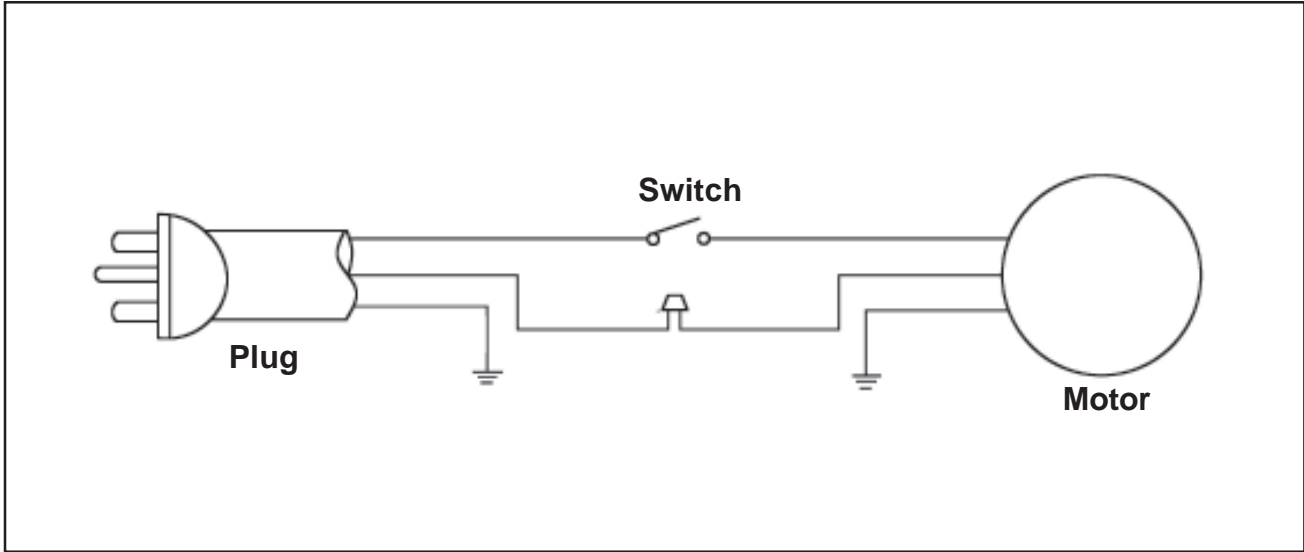

Fig. B

# Wiring Diagram

**WARNING:** This machine must be grounded.  
Replacement of the power supply cable should only be done by a qualified electrician.



# Troubleshooting

## Troubleshooting

### WARNING !

**FOR YOUR OWN SAFETY, ALWAYS TURN OFF AND UNPLUG THE MACHINE BEFORE CARRYING OUT ANY TROUBLESHOOTING**

Symptom	Possible Cause	Solution
Motor will not start	Machine not plugged in Low voltage Loose connection	Plug the machine in
Motor overheats	Motor overloaded Air flow restricted on motor	Reduce load on motor Clean out motor to obtain normal air flow
Excessive motor noise	Bad motor Pulley set screw loose	Have motor checked Tighten set screw
Motor will not develop full power or stalls	Circuit overloaded with lights or other tools Circuit too long or undersized wires Voltage too low Circuit breakers do not have sufficient capacity Drive belt tension too high Use of extension cord	Decrease the load on the circuit Reduce the length of the wire or increase the wire size Have the voltage checked by an electrician Have a licensed electrician install proper size breaker Adjust belt tension Use heavier gauge extension cord or no extension cord
Machine bogs down during cutting	Excessive depth of cut Turning tools are dull	Decrease depth of cut Sharpen turning tools

\*\*\*\*\*WARNING\*\*\*\*\*

**Do not make adjustments while the lathe is running. Ensure the switch is off, power is disconnected and all moving parts have stopped before servicing. Failure to comply may result in serious injury.**

# Explosion Diagram

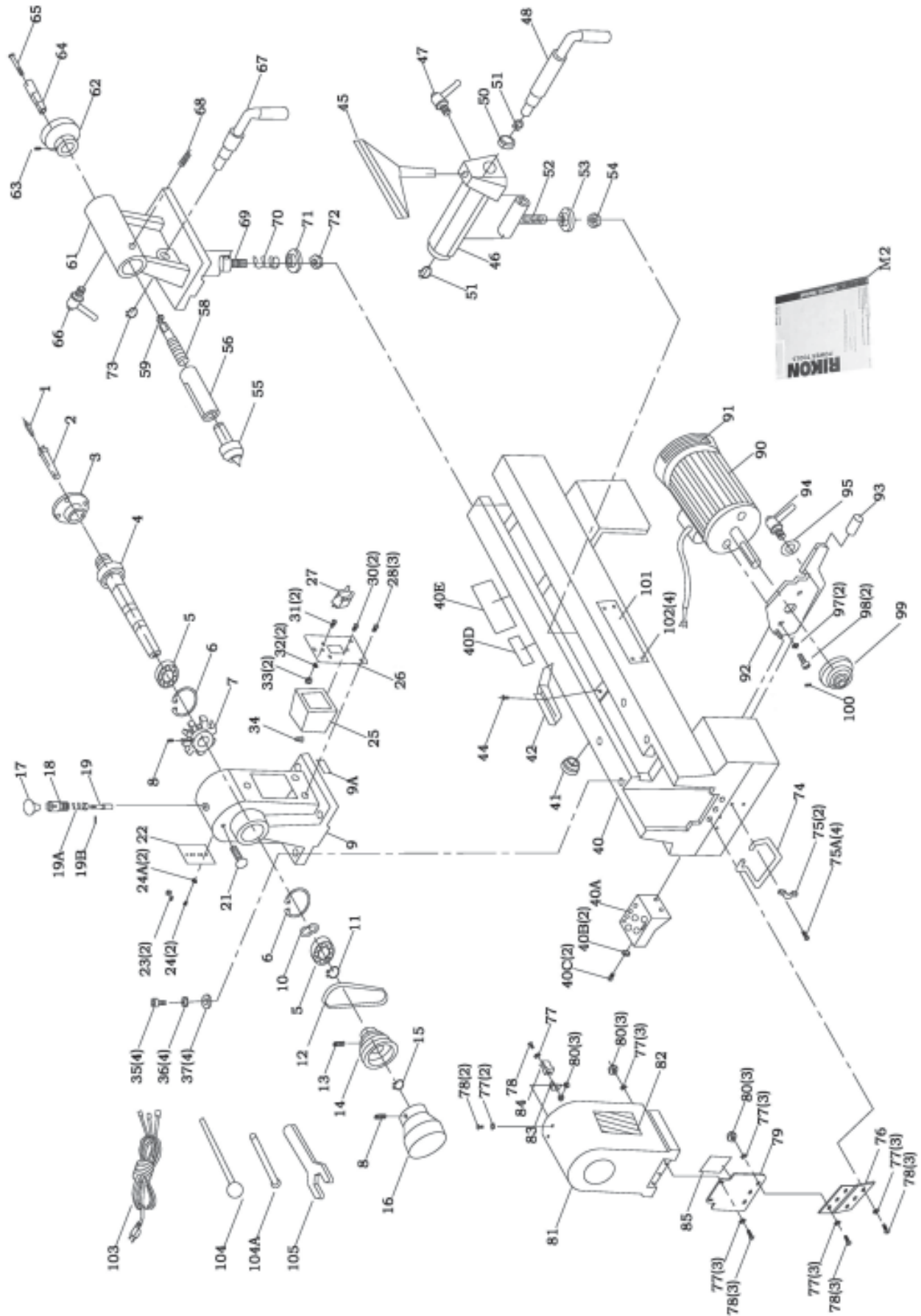

# Parts List

KEY No.	Description	Part No.	KEY No.	Description	Part No.
70-100 1	Center point	1-JL93010001	70-100 51	Ring retaining 12mm	1-CLP12GB894D1B
70-100 2	Spur center	1-JL93010002	70-100 52	Clamp bolt cover	1-JL93020005
70-100 3	Faceplate	1-JL93010003-001Y	70-100 53	Position plate	1-JL93030012
70-100 4	Spindle shaft	1-JL93010004	70-100 54	Lock nut M10	1-M10GB889Z
70-100 5	Bearing 6005-2Z	1-BRG6005-2RSV2	70-100 55	Live center	1-JL93031000
70-100 6	Ring retaining 47mm	1-CLP47GB893D1B	70-100 56	Axle sleeve	1-JL93030001
70-100 7	Indexing gear	1-JL93010006	70-100 58	Bolt	1-JL93030003
70-100 8	Hex socket set screw M6x8	1-M6X8GB80B	70-100 59	Ring retaining	1-CLP12GB896B
70-100 9	Spindle head	1-JL93010007-050W	70-100 61	Tail stock	1-JL93030005-050W
70-100 9A	Warning label	1-RK93081006	70-100 62	Handwheel	1-JL90030006
70-100 10	Wave washer 47mm	1-JL93010008	70-100 63	Hex. Socket set screw M6x12	1-M6X12GB80B
70-100 11	Ring retaining 25mm	1-CLP25GB894D1B	70-100 64	Handwheel handle	1-JL93030007
70-100 12	Poly-v-belt	1-JL93010009	70-100 65	Screw	1-JL93030009
70-100 13	Hex socket set screw M6x12	1-M6X12GB80B	70-100 66	Lock arm	1-JL93021000
70-100 14	Spindle pulley	1-JL93010010	70-100 67	Lock lever	1-JL93030009
70-100 15	Ring retaining 19mm	1-CLP19GB894D1B	70-100 68	Hex. Socket set screw M5x8	1-M5X8GB77B
70-100 16	Handwheel	1-JL93010011	70-100 69	Scr shaft	1-JL93030010
70-100 17	Spindle lock knob	1-0804011-01001S	70-100 70	Spring	1-JL93030011
70-100 18	Spindle lock tube	1-JL93010013	70-100 71	Clamp plate	1-JL93030012
70-100 19	Spindle lock shaft	1-JL93010015	70-100 72	Lock nut M10	1-M10GB889Z
70-100 19A	Spindle lock spring	1-JL93010014	70-100 73	Ring retaining 10mm	1-CLP10GB894D1B
70-100 19B	Pin roll 3x16	1-PIN3X16GB879D1B	70-100 74	Lifting handle	1-JL93050001
70-100 21	Rounded insert	1-JL93010016	70-100 75	Lifting handle clamping	1-JL93050002
70-100 22	Power cable plate	1-JL93040001	70-100 75A	Pan head screw M5x10	1-M5X10GB818B
70-100 23	Strain relief	1-403106	70-100 76	Hinge	1-JL93050003
70-100 24	Pan head screw M5x12	1-M5X12GB818B	70-100 77	Lock washer M4	1-WSH4GB862D1B
70-100 24A	Locking washer M5	1-WSH5GB862D2B	70-100 78	Pan head screw M4x10	1-M4X10GB818B
70-100 25	Box switch	1-JL93040002-001S	70-100 79	Motor pulley cover	1-JL93050004-001Z
70-100 26	Switch plate	1-JL93040003	70-100 80	Hex. Nut M4	1-M4GB6170B
70-100 27	Lock switch	1-J-9301B	70-100 81	Access cover	1-JL93050005-001S
70-100 28	Pan head screw M6x10	1-M6X10GB818B	70-100 82	Warning label	1-RK93081004
70-100 30	Pan head tapping screw ST4.2x22	1-ST4D2X25GB845B	70-100 83	Lock housing bracket	1-JL93050006
70-100 31	Pan head screw M4x10	1-M4X10GB818B	70-100 84	Lock housing	1-JL93050007
70-100 32	Locking washer M4	1-WSH4GB862D1B	70-100 85	Belt position chart	1-RK93081003
70-100 33	Hex. Nut M4	1-M4GB6170Z	70-100 90	Motor	1-H3612624
70-100 34	Close-end connector	1-JL93040008	70-100 91	Motor label	1-RK93081009
70-100 35	Hex. Socket head screw M6x35	1-M6X35GB70B	70-100 92	Belt tension handle	1-JL93041000
70-100 36	Spring washer 6mm	1-WSH6GB93B	70-100 93	Belt tension handle cover	1-JL93040005
70-100 37	Washer 6mm	1-WSH6GB97D1Z	70-100 94	Locking arm	1-JL93021000B
70-100 40	Bed	1-JL93010021-049W	70-100 95	Special washer 8mm	1-JL93040007
70-100 40A	Tool holder	1-JL93010017-001S	70-100 97	Spring washer 6mm	1-WSH6GB93B
70-100 40B	Washer 6mm	1-WSH6 GB97D1B	70-100 98	Hex. Socket head screw M6x15	1-M6X15GB70B
70-100 40C	Pan head screw M6x16	1-M6X16GB818B	70-100 99	Motor pulley	1-JL93040006
70-100 40D	Name label	1-RK93081002	70-100 100	Hex. Socket set screw M6x12	1-M6X12GB78B
70-100 40E	Warning label	1-RK93081005	70-100 101	Brand label	1-RK93081001
70-100 41	Cable tube	1-JL93040004-001S	70-100 102	Rivet M2.5x5	1-RVT2D5X5GB827C
70-100 42	Fence	1-JL93010019-001Z	70-100 103	Power cable	1-U23182300-472
70-100 44	Pan head screw M5x10	1-M5X10GB818B	70-100 104	Knokout bar	1-JL93070002
70-100 45	8" tool holder	1-JL93020001-001G	70-100 104A	Knokout bar	1-JL93070001
70-100 46	Tool holder seat	1-JL93020002-105L	70-100 105	Wrench	1-JL93070003
70-100 47	Lock arm	1-JL930210000A	70-100 M2	Manual	1-RK93082006
70-100 48	Lock lever	1-JL93020003			
70-100 50	Collar	1-JL93020004			

## Warranty



### **2-Year Limited Warranty**

RIKON Power Tools/Richen Enterprise, Inc. (“Seller”) warrants to only the original retail consumer/purchaser of our products that each product be free from defects in materials and workmanship for a period of two (2) years from the date the product was purchased at retail. This warranty may not be transferred.

This warranty does not apply to defects due directly or indirectly to misuse, abuse, negligence, accidents, repairs, alterations, lack of maintenance or normal wear and tear. Under no circumstances will Seller be liable for incidental or consequential damages resulting from defective products. All other warranties, expressed or implied, whether of merchantability, fitness for purpose, or otherwise are expressly disclaimed by Seller. This warranty does not cover products used for commercial, industrial or educational purposes.

This limited warranty does not apply to accessory items such as blades, drill bits, sanding discs or belts and other related items.

Seller shall in no event be liable for death, injuries to persons or property, or for incidental, contingent, special, or consequential damages arising from the use of our products.

To take advantage of this warranty proof of purchase documentation, which includes date of purchase and an explanation of the complaint, must be provided.

The Seller reserves the right to effect at any time, without prior notice, those alterations to parts, fittings, and accessory equipment which they may deem necessary for any reason whatsoever.

To take advantage of this warranty, please fill out the enclosed warranty card and send it to:  
RIKON Warranty  
110 Cummings Park  
Woburn, MA 01801

The card must be entirely completed in order for it to be valid. If you have any questions please contact us at 877-884-5167 or [warranty@rikontools.com](mailto:warranty@rikontools.com).

**Notes:**

# **RIKON** **POWER TOOLS**

**For more information:  
110 Cummings Park  
Woburn, MA 01801**

**877-884-5167 / 781-933-8400  
techsupport@rikontools.com  
www.rikontools.com**